

TOOL HOLDERS

HSK-T

HSK-T TOOLING SYSTEM

HSK-T 工具系统

HSK-T Boring Bar Holder004 复合刀具, 镗孔刀夹	HSK-T Turning Tool 长型 DDQNR DDQNL 107.5°/55°033 负前角刀片
HSK-T Turning Tools for Facing005 复合车刀座, 端面加工	HSK-T Turning Tool 长型 PDQNR PDQNL 107.5°/55°034 负前角刀片
HSK-T Turning Tools for External and Facing006 复合车刀座, 外径端面加工	HSK-T Turning Tool SCLCR SCLCL 95°/80°035 正前角刀片
HSK-T Turning Tools for External and Cut-off007 复合车刀座, 外径切断加工	HSK-T Turning Tool SCMCN 50°/80°/50°036 正前角刀片
HSK-T Turning Tools for External and Facing008 复合车刀座, 外径端面加工	HSK-T Turning Tool SDHCR SDHCL 107.5°/55°037 正前角刀片
HSK-T Turning Tools for Internal009 复合车刀座, 内孔加工	HSK-T Turning Tool SDNCN 62.5°/55°/62.5°038 正前角刀片
HSK-T Turning Tool DCLNR DCLNL 95°/80°011 负前角刀片	HSK-T Turning Tool SDJCR SDJCL 93°/55°039 正前角刀片
HSK-T Turning Tool PCLNR PCLNL 95°/80°012 负前角刀片	HSK-T Turning Tool SDUCR SDUCL 93°/55°040 正前角刀片
HSK-T Turning Tool DCMNN 50°/80°/50°013 负前角刀片	HSK-T Turning Tool SSBGR SSBCL 75°/90°041 正前角刀片
HSK-T Turning Tool PCMNN 50°/80°/50°014 负前角刀片	HSK-T Turning Tool SSSCR SSSCL 45°/90°042 正前角刀片
HSK-T Turning Tool DDJNR DDJNL 55°/93°015 负前角刀片	HSK-T Turning Tool SVPBR SVPBL SVPCR SVPL 117.5°/35°043 正前角刀片
HSK-T Turning Tool PDJNR PDJNL 55°/93°016 负前角刀片	HSK-T Turning Tool SVUBR SVUBL SVUCR SVUCL 93°/35°044 正前角刀片
HSK-T Turning Tool DDNNN 62.5°/55°/62.5°017 负前角刀片	HSK-T Turning Tool SWBN SWCN 72.5°/35°/72.5°045 正前角刀片
HSK-T Turning Tool PDNNN 62.5°/55°/62.5°018 负前角刀片	HSK-T Turning Tool SVJBR SVJBL SVJCR SVJCL 93°/35°046 正前角刀片
HSK-T Turning Tool DDUNR DDUNL 93°/55°019 负前角刀片	HSK-T Turning Tool SCLCR SCLCL 95°/80°047 正前角刀片
HSK-T Turning Tool PDUNR PDUNL 93°/55°020 负前角刀片	HSK-T Turning Tool 长型 SDQCR SDQCL 107.5°/55°048 正前角刀片
HSK-T Turning Tool DSBNR DSBNL 90°/75°021 负前角刀片	HSK-T Turning Tool 长型 SVQCR SVQCL 107.5°/55°049 正前角刀片
HSK-T Turning Tool PSBGR PSBNL 90°/75°022 负前角刀片	
HSK-T Turning Tool DSSNR DSSNL 45°/90°023 负前角刀片	
HSK-T Turning Tool PSSNR PSSNL 45°/90°024 负前角刀片	
HSK-T Turning Tool DVPNR DVPNL 117.5°/35°025 负前角刀片	
HSK-T Turning Tool DVUNR DVUNL 93°/35°026 负前角刀片	
HSK-T Turning Tool DVVNN 72.5°/35°/72.5°027 负前角刀片	
HSK-T Turning Tool DVJNR DVJNL 93°/35°028 负前角刀片	
HSK-T Turning Tool DWLNR DWLNL 95°/80°029 负前角刀片	
HSK-T Turning Tool PWLNR PWLNL 95°/80°030 负前角刀片	
HSK-T Turning Tool 长型 DCLNR DCLNL 95°/80°031 负前角刀片	
HSK-T Turning Tool 长型 PCLNR PCLNL 95°/80°032 负前角刀片	



HSK-T Boring Bar Holder

复合刀具, 镗孔刀夹

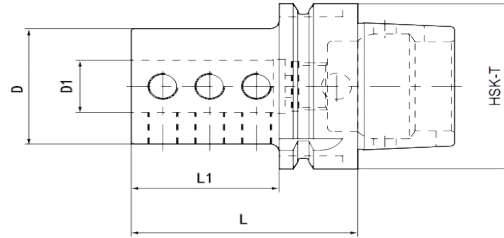

Size	D1	D	L	L1
HSK40T-E2-06-055	6	34	55	35
HSK40T-E2-08-055	8	34	55	35
HSK40T-E2-10-055	10	34	55	35
HSK40T-E2-12-055	12	36	55	35
HSK40T-E2-16-070	16	40	70	50
HSK40T-E2-20-085	20	44	85	65
HSK63T-E2-06-060	6	34	60	34
HSK63T-E2-08-060	8	34	60	34
HSK63T-E2-10-060	10	34	60	34
HSK63T-E2-12-060	12	36	60	34
HSK63T-E2-16-075	16	40	75	49
HSK63T-E2-20-075	20	44	75	49
HSK63T-E2-25-075	25	50	75	49
HSK63T-E2-32-090	32	56	90	64
HSK63T-E2-40-090	40	63	90	64
HSK100T-E2-06-070	6	34	70	41
HSK100T-E2-08-070	8	34	70	41
HSK100T-E2-10-070	10	34	70	41
HSK100T-E2-12-070	12	36	70	41
HSK100T-E2-16-085	16	40	85	56
HSK100T-E2-20-085	20	44	85	56
HSK100T-E2-25-085	25	50	85	56
HSK100T-E2-32-100	32	56	100	71
HSK100T-E2-40-100	40	63	100	71
HSK100T-E2-50-120	50	88	120	91

HSK·T Turning Tools for Facing
复合车刀座, 端面加工

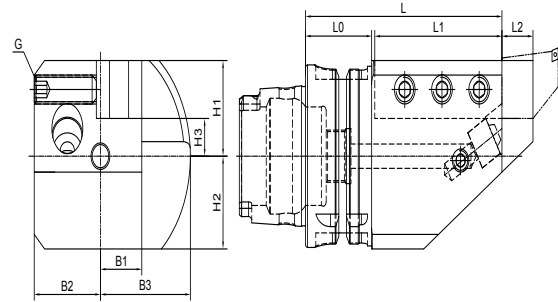

Size	L	L1	L2	B1	B2	B3	H1	H2	H3	G
HSK50T-SBV2020R-105	105	60	15	20	25	43.5	25	25	5	M10
HSK50T-SBV2020L-105	105	60	15	20	25	43.5	25	25	5	M10
HSK63T-SBV2020R-105	105	60	15	20	32	43.5	33	32	13	M10
HSK63T-SBV2020L-105	105	60	15	20	32	43.5	33	32	13	M10
HSK63T-SBV2525R-115	115	70	20	25	32	45	30	30	5	M12
HSK63T-SBV2525L-115	115	70	20	25	32	45	30	30	5	M12
HSK100T-SBV2525R-160	160	110	20	25	37	59	48	43	23	M12
HSK100T-SBV2525L-160	160	110	20	25	37	59	48	43	23	M12
HSK100T-SBV3232R-160	160	110	20	32	40	68.5	45	43	15	M14
HSK100T-SBV3232L-160	160	110	20	32	40	68.5	45	43	15	M14

HSK

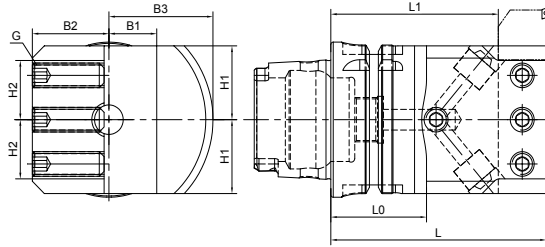
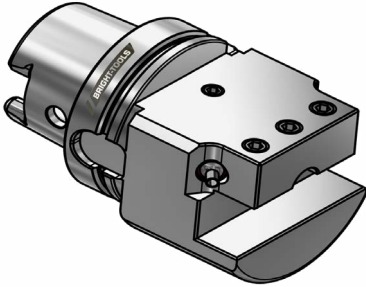
HSK-T Turning Tools for External and Facing
复合车刀座, 外径端面加工

Size	L	L1	B1	B2	B3	H1	H2	G
HSK50T-SBH2020N-100	100	80	20	25	43.5	27.5	-	M10
HSK50T-SBH2020N-130	130	110	20	25	43.5	27.5	-	M10
HSK63T-SBH2020N-100	100	80	20	32	43.5	30	-	M10
HSK63T-SBH2525N-100	100	75	25	32	53	40.5	29.5	M12
HSK63T-SBH2525N-130	130	105	25	32	53	40.5	29.5	M12
HSK100T-SBH2525N-115	115	90	25	32	59	48	37	M12
HSK100T-SBH2525N-160	160	135	25	32	59	48	37	M12
HSK100T-SBH3232N-115	115	85	32	40	68.5	57	43	M14

HSK-T Turning Tools for External and Cut-off

复合车刀座, 外径切断加工

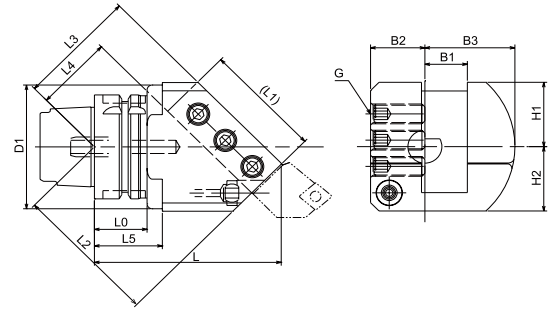

Size	L	L1	L2	L3	L4	D1	B1	B2	B3	H1	H2	G
HSK50T-SBN2020R-120	120	60	83.1	72.8	52.8	-	20	25	43.5	35	35	M10
HSK50T-SBN2020L-120	120	60	83.1	72.8	52.8	-	20	25	43.5	35	35	M10
HSK63T-SBN2020R-120	120	60	83.1	72.8	52.8	-	20	32	43.5	35	35	M10
HSK63T-SBN2020L-120	120	60	83.1	72.8	52.8	-	20	32	43.5	35	35	M10
HSK63T-SBN2525R-120	120	70	85.2	70.8	45.8	90	25	32	53	39	39	M12
HSK63T-SBN2525L-120	120	70	85.2	70.8	45.8	90	25	32	53	39	39	M12
HSK100T-SBN2525R-145	145	70	102.9	88.5	63.5	-	25	32	59	43	43	M12
HSK100T-SBN2525L-145	145	70	102.9	88.5	63.5	-	25	32	59	43	43	M12
HSK100T-SBN3232R-150	150	85	109.9	89	59	-	32	37	68.5	48	43	M14
HSK100T-SBN3232L-150	150	85	109.9	89	59	-	32	37	68.5	48	43	M14

HSK

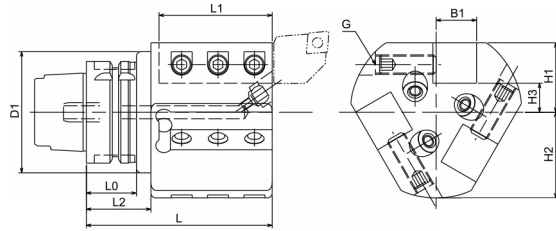
HSK-T Turning Tools for External and Facing
复合车刀座, 外径端面加工

Size	L	L1	L2	D1	B1	H1	H2	H3	G
HSK50T-SBT2020R-105	105	60	-	-	20	35	43.5	15	M10
HSK50T-SBT2020L-105	105	60	-	-	20	35	43.5	15	M10
			-	-	20	35	43.5	15	M10
HSK63T-SBT2020R-105	105	60	-	-	20	35	43.5	15	M10
HSK63T-SBT2020L-105	105	60							
HSK63T-SBT2525R-125	125	70	40	90	25	43	53	18	M12
HSK63T-SBT2525L-125	125	70	40	90	25	43	53	18	M12
HSK100T-SBT2525R-160	160	110	-	-	25	48	59	23	M12
HSK100T-SBT2525L-160	160	110	-	-	25	48	59	23	M12

HSK-T Turning Tools for Internal
复合车刀座, 内孔加工

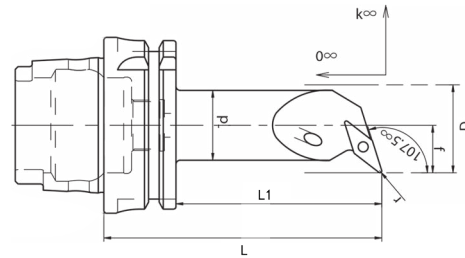

Size	d	L	L1	f	k°	D	r	Inserts N.
HSK63T-SVQBR11-85	20	85	59	13	-8	25	0.4	VB..1102..
HSK63T-SVQBL11-85	20	85	59	13	-8	25	0.4	VB..1102..
HSK63T-SVQBR11-100	25	100	74	17	-5	32	0.4	VB..1102..
HSK63T-SVQBL11-100	25	100	74	17	-5	32	0.4	VB..1102..
HSK63T-SVQBR16-120	32	120	94	22	-10	40	0.8	VB..1604..
HSK63T-SVQBL16-120	32	120	94	22	-10	40	0.8	VB..1604..
HSK63T-SVQBR16-140	40	140	114	27	-10	50	0.8	VB..1604..
HSK63T-SVQBL16-140	40	140	114	27	-10	50	0.8	VB..1604..

HSK

HSK-T Turning Tool DCLNR | DCLNL 95°/80°
负前角刀片

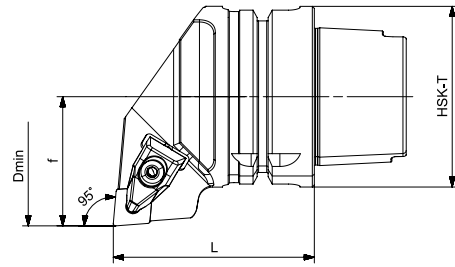

Size	f	D	L	Direction	Inserts N.
HSK63T-DCLNR12-70-45	45	80	70	R	CN..1204..
HSK63T-DCLNL12-70-45	45	80	70	L	CN..1204..
HSK63T-DCLNR16-70-45	45	80	70	R	CN..1606..
HSK63T-DCLNL16-70-45	45	80	70	L	CN..1606..
HSK100T-DCLNR12-100-63	63	120	100	R	CN..1204..
HSK100T-DCLNL12-100-63	63	120	100	L	CN..1204..
HSK100T-DCLNR16-100-63	63	120	100	R	CN..1606..
HSK100T-DCLNL16-100-63	63	120	100	L	CN..1606..

HSK

HSK-T Turning Tool PCLNR | PCLNL 95°/80°

负前角刀片

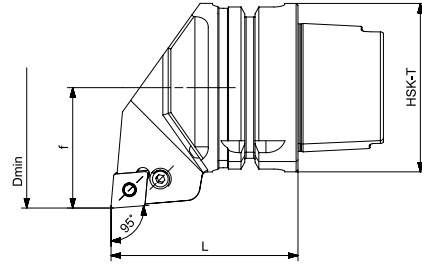

Size	f	D	L	Direction	Inserts N.
HSK63T-PCLNR12-70-45	45	80	70	R	CN..1204..
HSK63T-PCLNL12-70-45	45	80	70	L	CN..1204..
HSK63T-PCLNR16-70-45	45	80	70	R	CN..1606..
HSK63T-PCLNL16-70-45	45	80	70	L	CN..1606..
HSK100T-PCLNR12-100-63	63	120	100	R	CN..1204..
HSK100T-PCLNL12-100-63	63	120	100	L	CN..1204..
HSK100T-PCLNR16-100-63	63	120	100	R	CN..1606..
HSK100T-PCLNL16-100-63	63	120	100	L	CN..1606..
HSK100T-PCLNR19-100-63	63	120	100	R	CN..1906..
HSK100T-PCLNL19-100-63	63	120	100	L	CN..1906..

HSK-T Turning Tool DCMNN 50°/80°/50°
负前角刀片

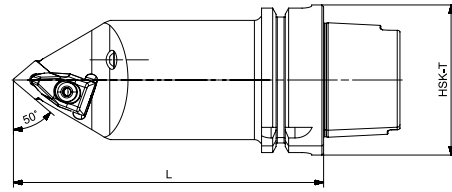

Size	L	Direction	Inserts N.
HSK63T-DCMNN12-100-0	100	N	CN..1204..
HSK63T-DCMNN12-130-0	130	N	CN..1204..
HSK63T-DCMNN12-100-0	100	N	CN..1606..
HSK63T-DCMNN12-130-0	130	N	CN..1606..
HSK100T-DCMNN12-125-0	125	N	CN..1204..
HSK100T-DCMNN12-125-0	125	N	CN..1606..

HSK-T Turning Tool PCMNN 50°/80°/50°

负前角刀片

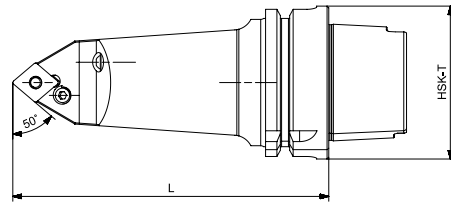

Size	L	Direction	Inserts N.
HSK63T-PCMNN12-100-0	100	N	CN..1204..
HSK63T-PCMNN12-130-0	130	N	CN..1204..
HSK63T-PCMNN12-100-0	100	N	CN..1606..
HSK63T-PCMNN12-130-0	130	N	CN..1606..
HSK100T-PCMNN12-125-0	125	N	CN..1204..
HSK100T-PCMNN12-125-0	125	N	CN..1606..

HSK-T Turning Tool DDJNR | DDJNL 55°/93°
负前角刀片

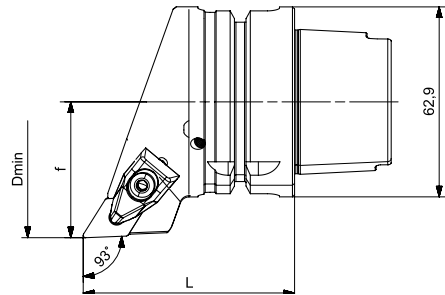

Size	f	D	L	Direction	Inserts N.
HSK63T-DDJNR15-75-45	45	-	70	R	DN..1506..
HSK63T-DDJNL15-75-45	45	-	70	L	DN..1506..
HSK100T-DDJNR15-100-63	63	-	100	R	DN..1506..
HSK100T-DDJNL15-100-63	63	-	100	L	DN..1506..

HSK

HSK-T Turning Tool PDJNR | PDJNL 55°/93°

负前角刀片

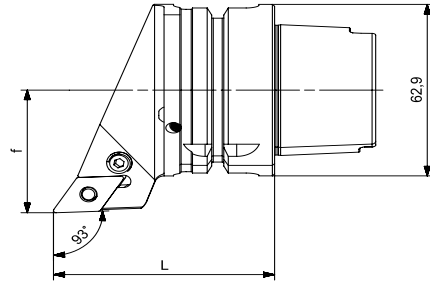

Size	f	D	L	Direction	Inserts N.
HSK63T-PDJNR15-70-45	45	-	70	R	DN..1506..
HSK63T-PDJNL15-70-45	45	-	70	L	DN..1506..
HSK100T-PDJNR15-100-63	63	-	100	R	DN..1506..
HSK100T-PDJNL15-100-63	63	-	100	L	DN..1506..

HSK-T Turning Tool DDNNN 62.5°/55°/62.5°

负前角刀片

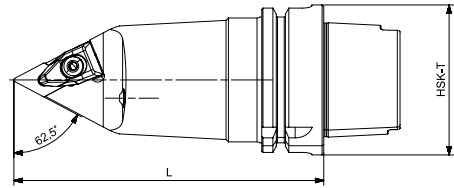

Size	L	Direction	Inserts N.
HSK63T-DDNNN15-100-0	100	N	DN..1506..
HSK63T-DDNNN15-130-0	130	N	DN..1506..
HSK100T-DDNNN15-125-0	125	N	DN..1506..

HSK

HSK-T Turning Tool PDNNN 62.5°/55°/62.5°

负前角刀片

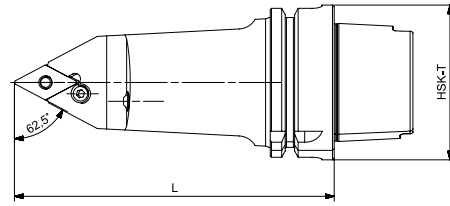

Size	L	Direction	Inserts N.
HSK63T-PDNNN15-100-0	100	N	DN..1506..
HSK63T-PDNNN15-130-0	130	N	DN..1506..
HSK100T-PDNNN15-125-0	125	N	DN..1506.. DN..1506..

HSK-T Turning Tool DDUNR | DDUNL 93°/55°
负前角刀片

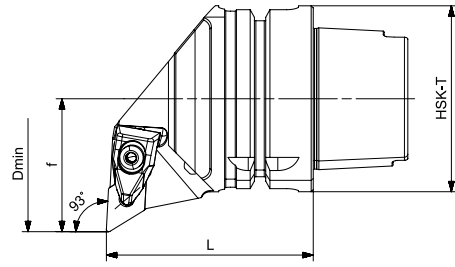

Size	f	D	L	Direction	Inserts N.
HSK63T-DDUNR15-70-45	45	80	70	R	DN..1506..
HSK63T-DDUNL15-70-45	45	80	70	L	DN..1506..
HSK100T-DDUNR15-100-63	63	120	100	R	DN..1506..
HSK100T-DDUNL15-100-63	63	120	100	L	DN..1506..

HSK-T Turning Tool PDUNR | PDUNL 93°/55°

负前角刀片

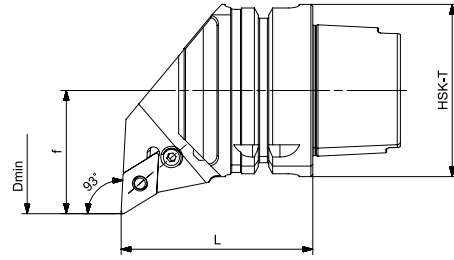

Size	f	D	L	Direction	Inserts N.
HSK63T-PDUNR15-70-45	45	80	70	R	DN..1506..
HSK63T-PDUNL15-70-45	45	80	70	L	DN..1506..
HSK100T-PDUNR15-100-63	63	120	100	R	DN..1506..
HSK100T-PDUNL15-100-63	63	120	100	L	DN..1506..

HSK-T Turning Tool DSBNR | DSBNL 90°/75°
负前角刀片

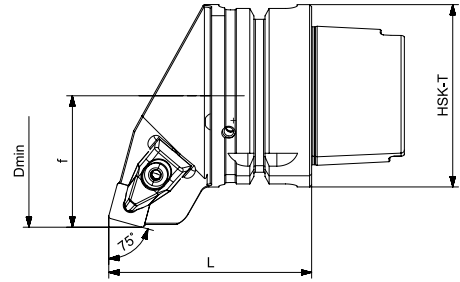

Size	f	D	L	Direction	Inserts N.
HSK63T-DSB NR12-70-45	45	-	70	R	SN..1204..
HSK63T-DSB NL12-70-45	45	-	70	L	SN..1204..
HSK100T-DSB NR12-100-63	63	-	100	R	SN..1204..
HSK100T-DSB NL12-100-63	63	-	100	L	SN..1204..

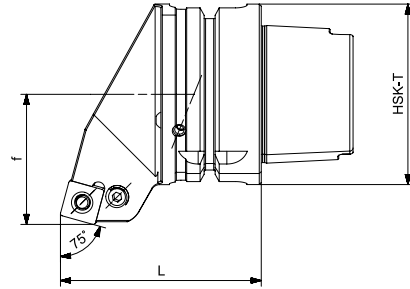
HSK-T Turning Tool PSBNR | PSBNL 90°/75°
负前角刀片

Size	f	D	L	Direction	Inserts N.
HSK63T-PSBNR12-70-45	45	-	70	R	SN..1204..
HSK63T-PSBNL12-70-45	45	-	70	L	SN..1204..
HSK100T-PSBNR12-100-63	63	-	100	R	SN..12 04..
HSK100T-PSBNL12-100-63	63	-	100	L	SN..1204..

HSK-T Turning Tool DSSNR | DSSNL 45°/90°
负前角刀片

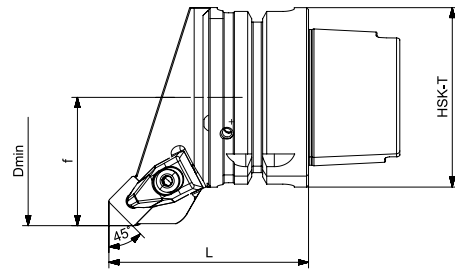

Size	f	D	L	Direction	Inserts N.
HSK63T-DSSNR12-70-45	45	-	70	R	SN..1204..
HSK63T-DSSNL12-70-45	45	-	70	L	SN..1204..
HSK100T-DSSNR12-100-63	63	-	100	R	SN..1204..
HSK100T-DSSNL12-100-63	63	-	100	L	SN..1204..

HSK-T Turning Tool PSSNR | PSSNL 45°/90°

负前角刀片

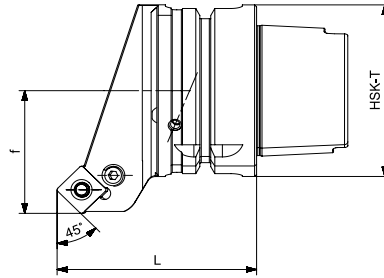

Size	f	D	L	Direction	Inserts N.
HSK63T-PSSNR12-70-45	45	-	70	R	SN..1204..
HSK63T-PSSNL12-70-45	45	-	70	L	SN..1204..
HSK100T-PSSNR12-100-63	63	-	100	R	SN..1204..
HSK100T-PSSNL12-100-63	63	-	100	L	SN..1204..

HSK-T Turning Tool DVPNR | DVPNL 117.5°/35°

负前角刀片

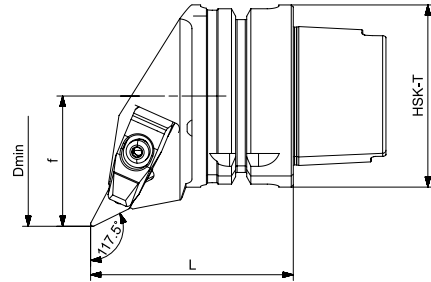

Size	f	D	L	Direction	Inserts N.
HSK63T-DVPNR16-70-45	45	80	70	R	VN..1604..
HSK63T-DVPNL16-70-45	45	80	70	L	VN..1604..
HSK100T-DVPNR16-100-63	63	120	100	R	VN..1604..
HSK100T-DVPNL16-100-63	63	120	100	L	VN..1604..

HSK

HSK-T Turning Tool DVUNR | DVUNL 93°/35°

负前角刀片

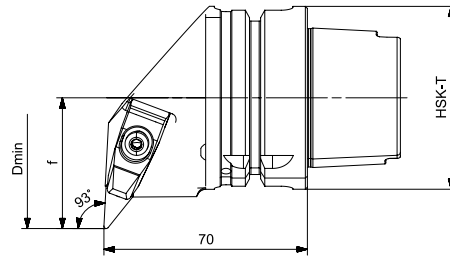

Size	f	D	L	Direction	Inserts N.
HSK63T-DVUNR16-70-45	45	80	70	R	VN..1604..
HSK63T-DVUNL16-70-45	45	80	70	L	VN..1604..
HSK100T-DVUNR16-100-63	63	120	100	R	VN..1604..
HSK100T-DVUNL16-100-63	63	120	100	L	VN..1604..

HSK-T Turning Tool DVVNN 72.5°/35°/72.5°

负前角刀片

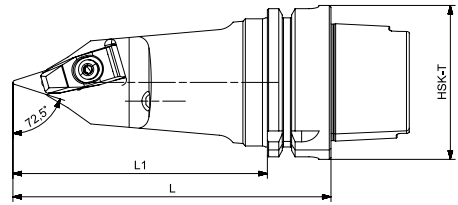

Size	f	D	L	Direction	Inserts N.
HSK63T-DVVNN16-100-0	-	-	100	N	VN..1604..
HSK63T-DVVNN16-130-0	-	-	130	N	VN..1604..
HSK100T-DVVNN16-125-0	-	-	125	N	VN..1604..

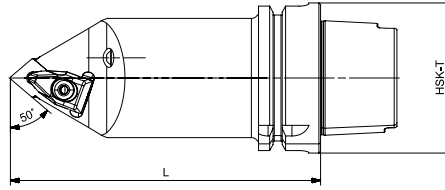
HSK-T Turning Tool DVJNR | DVJNL 93°/35°
负前角刀片

Size	f	D	L	Direction	Inserts N.
HSK100T-DVJNR16-100-63	63	-	100	R	VN..1604..
HSK100T-DVJNL16-100-63	63	-	100	L	VN..1604..

HSK-T Turning Tool DWLNR | DWLNL 95°/80°

负前角刀片

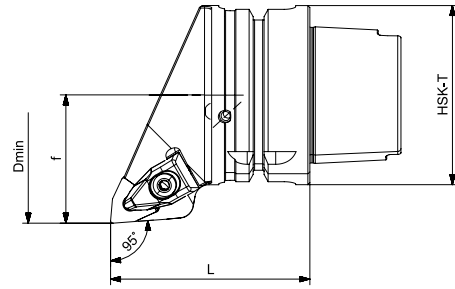

Size	f	D	L	Direction	Inserts N.
HSK63T-DWLNR8-70-45	45	80	70	R	WN..0804..
HSK63T-DWLNL8-70-45	45	80	70	L	WN..0804..
HSK100T-DWLNR8-100-63	63	120	100	R	WN..0804..
HSK100T-DWLNL8-100-63	63	120	100	L	WN..0804..

HSK

HSK-T Turning Tool PWLNR | PWLNL 95°/80°

负前角刀片

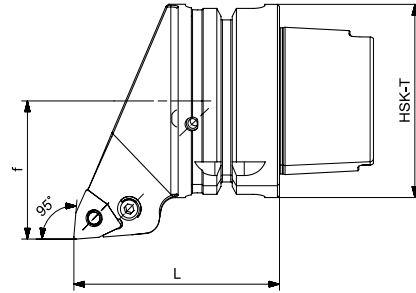

Size	f	D	L	Direction	Inserts N.
HSK63T-PWLNR8-70-45	45	80	70	R	WN..0804..
HSK63T-PWLNL8-70-45	45	80	70	L	WN..0804..
HSK100T-PWLNR8-100-63	63	120	100	R	WN..0804..
HSK100T-PWLNL8-100-63	63	120	100	L	WN..0804..

HSK-T Turning Tool 长型 DCLNR | DCLNL 95°/80°
负前角刀片

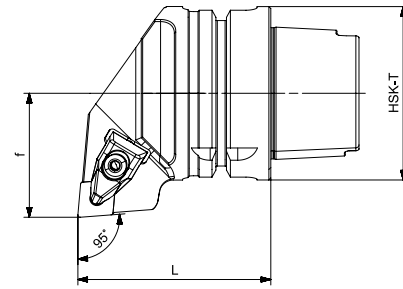

Size	f	D	L	L1	Direction	Inserts N.
HSK63T-DCLNR12-140-27	27	50	140	114	R	CN..1204..
HSK63T-DCLNL12-140-27	27	50	140	114	L	CN..1204..
HSK63T-DCLNR12-180-27	27	50	180	154	R	CN..1204..
HSK63T-DCLNL12-180-27	27	50	180	154	L	CN..1204..
HSK100T-DCLNR12-150-27	27	50	150	121	R	CN..1204..
HSK100T-DCLNL12-150-27	27	50	150	121	L	CN..1204..
HSK100T-DCLNR12-200-27	27	50	200	171	R	CN..1204..
HSK100T-DCLNL12-200-27	27	50	200	171	L	CN..1204..
HSK100T-DCLNR12-150-35	35	63	150	121	R	CN..1204..
HSK100T-DCLNL12-150-35	35	63	150	121	L	CN..1204..
HSK100T-DCLNR12-200-35	35	63	200	171	R	CN..1204..
HSK100T-DCLNL12-200-35	35	63	200	171	L	CN..1204..

HSK-T Turning Tool 长型 PCLNR | PCLNL 95°/80° 负前角刀片

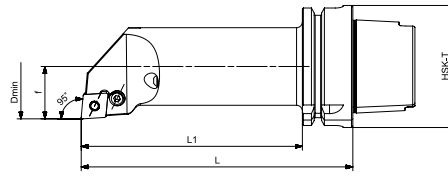
HSK

Size	f	D	L	L1	Direction	Inserts N.
HSK63T-PCLNR12-140-27	27	50	140	114	R	CN..1204..
HSK63T-PCLNL12-140-27	27	50	140	114	L	CN..1204..
HSK63T-PCLNR12-180-27	27	50	180	154	R	CN..1204..
HSK63T-PCLNL12-180-27	27	50	180	154	L	CN..1204..
HSK100T-PCLNR12-150-27	27	50	150	121	R	CN..1204..
HSK100T-PCLNL12-150-27	27	50	150	121	L	CN..1204..
HSK100T-PCLNR12-200-27	27	50	200	171	R	CN..1204..
HSK100T-PCLNL12-200-27	27	50	200	171	L	CN..1204..
HSK100T-PCLNR12-150-35	35	63	150	121	R	CN..1204..
HSK100T-PCLNL12-150-35	35	63	150	121	L	CN..1204..
HSK100T-PCLNR12-200-35	35	63	200	171	R	CN..1204..
HSK100T-PCLNL12-200-35	35	63	200	171	L	CN..1204..

**HSK-T Turning Tool 长型 DDQNR | DDQNL 107.5°/55°
负前角刀片**

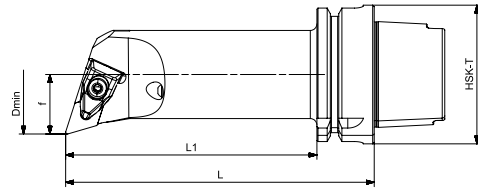

Size	f	D	L	L1	Direction	Inserts N.
HSK63T-DDQNR15-140-27	27	50	140	114	R	DN..1506..
HSK63T-DDQNL15-140-27	27	50	140	114	L	DN..1506..
HSK63T-DDQNR15-180-27	27	50	180	154	R	DN..1506..
HSK63T-DDQNL15-180-27	27	50	180	154	L	DN..1506..
HSK100T-DDQNR15-150-27	27	50	150	121	R	DN..1506..
HSK100T-DDQNL15-150-27	27	50	150	121	L	DN..1506..
HSK100T-DDQNR15-200-27	27	50	200	171	R	DN..1506..
HSK100T-DDQNL15-200-27	27	50	200	171	L	DN..1506..
HSK100T-DDQNR15-150-35	35	63	150	121	R	DN..1506..
HSK100T-DDQNL15-150-35	35	63	150	121	L	DN..1506..
HSK100T-DDQNR15-200-35	35	63	200	171	R	DN..1506..
HSK100T-DDQNL15-200-35	35	63	200	171	L	DN..1506..

HSK-T Turning Tool 长型 PDQNR | PDQNL 107.5°/55°

负前角刀片

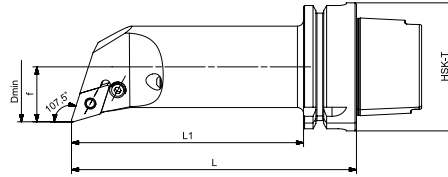

Size	f	D	L	L1	Direction	Inserts N.
HSK63T-PDQNR15-140-27	27	50	140	114	R	DN..1506..
HSK63T-PDQNL15-140-27	27	50	140	114	L	DN..1506..
HSK63T-PDQNR15-180-27	27	50	180	154	R	DN..1506..
HSK63T-PDQNL15-180-27	27	50	180	154	L	DN..1506..
HSK100T-PDQNR15-150-27	27	50	150	121	R	DN..1506..
HSK100T-PDQNL15-150-27	27	50	150	121	L	DN..1506..
HSK100T-PDQNR15-200-27	27	50	200	171	R	DN..1506..
HSK100T-PDQNL15-200-27	27	50	200	171	L	DN..1506..
HSK100T-PDQNR15-150-35	35	63	150	121	R	DN..1506..
HSK100T-PDQNL15-150-35	35	63	150	121	L	DN..1506..
HSK100T-PDQNR15-200-35	35	63	200	171	R	DN..1506..
HSK100T-PDQNL15-200-35	35	63	200	171	L	DN..1506..

HSK-T Turning Tool SCLCR | SCLCL 95°/80°
正前角刀片

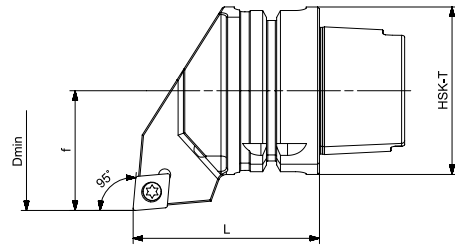

Size	f	D	L	Direction	Inserts N.
HSK63T-SCLCR12-70-45	45	80	70	R	CC..1204..
HSK63T-SCLCL12-70-45	45	80	70	L	CC..1204..
HSK100T-SCLCR12-100-63	63	120	100	R	CC..1204..
HSK100T-SCLCL12-100-63	63	120	100	L	CC..1204..

HSK-T Turning Tool SCMCN 50°/80°/50°

正前角刀片

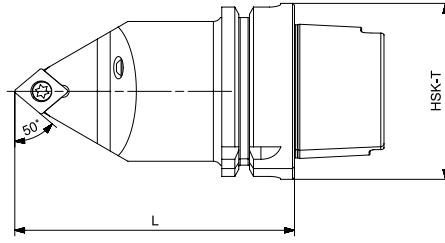

Size	L	Direction	Inserts N.
HSK63T-SCMCN12-100-0	100	N	CC..1204..
HSK63T-SCMCN12-130-0	130	N	CC..1204..
HSK100T-SCMCN12-125-0	125	N	CC..1204..

HSK-T Turning Tool SDHCR | SDHCL 107.5°/55°

正前角刀片

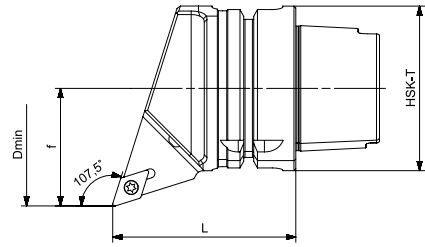

Size	f	D	L	Direction	Inserts N.
HSK63T-SDHCR11-70-45	45	80	70	R	DC..11T3..
HSK63T-SDHCL11-70-45	45	80	70	L	DC..11T3..
HSK100T-SDHCR11-100-63	63	120	100	R	DC..11T3..
HSK100T-SDHCL11-100-63	63	120	100	L	DC..11T3..

HSK-T Turning Tool SDNCN 62.5°/55°/62.5°

正前角刀片

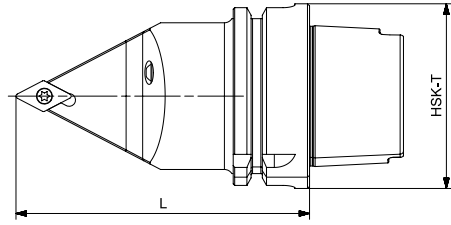

Size	L	Direction	Inserts N.
HSK63T-SDNCN11-100-0	100	N	DC..11T3..
HSK63T-SDNCN11-130-0	130	N	DC..11T3..
HSK100T-SDNCN11-125-0	125	N	DC..11T3..

HSK-T Turning Tool SDJCR | SDJCL 93°/55°
正前角刀片

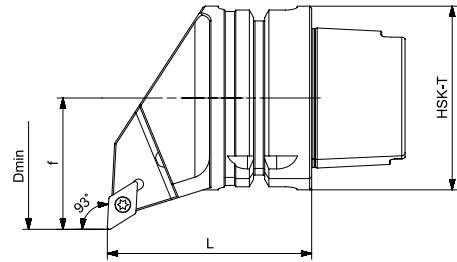

Size	f	D	L	Direction	Inserts N.
HSK63T-SDJCR11-70-45	45	80	70	R	DC..11T3..
HSK63T-SDJCL11-70-45	45	80	70	L	DC..11T3..
HSK100T-SDJCR11-100-63	63	120	100	R	DC..11T3..
HSK100T-SDJCL11-100-63	63	120	100	L	DC..11T3..

HSK-T Turning Tool SDUCR | SDUCL 93°/55°

正前角刀片

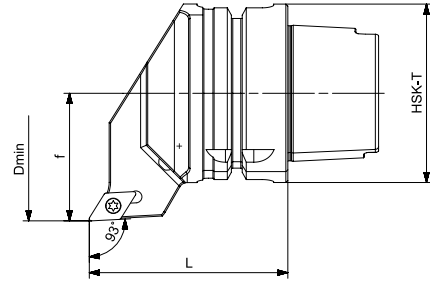

Size	f	D	L	Direction	Inserts N.
HSK63T-SDUCR11-70-45	45	80	70	R	DC..11T3..
HSK63T-SDUCL11-70-45	45	80	70	L	DC..11T3..
HSK100T-SDUCR11-100-63	63	120	100	R	DC..11T3..
HSK100T-SDUCL11-100-63	63	120	100	L	DC..11T3..

HSK-T Turning Tool SSBCR | SSBCL 75°/90°
正前角刀片

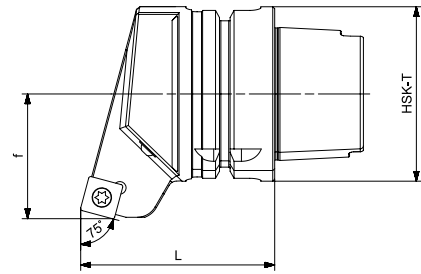

Size	f	D	L	Direction	Inserts N.
HSK63T-SSBCR12-70-45	45	-	70	R	SC..1204..
HSK63T-SSBCL12-70-45	45	-	70	L	SC..1204..
HSK100T-SSBCR12-100-63	63	-	100	R	SC..1204..
HSK100T-SSBCL12-100-63	63	-	100	L	SC..1204..

HSK-T Turning Tool SSSCR | SSSCL 45°/90°

正前角刀片

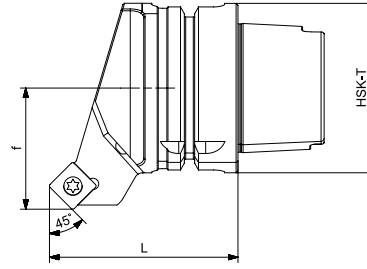

Size	f	D	L	Direction	Inserts N.
HSK63T-SSSCR12-70-45	45	-	70	R	SC..1204..
HSK63T-SSSCL12-70-45	45	-	70	L	SC..1204..
HSK100T-SSSCR12-100-63	63	-	100	R	SC..1204..
HSK100T-SSSCL12-100-63	63	-	100	L	SC..1204..

HSK-T Turning Tool SVPBR | SVPBL | SVPCR | SVPCL 117.5°/35°

正前角刀片

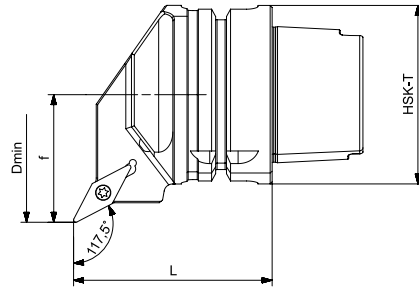

Size	f	D	L	Direction	Inserts N.
HSK63T-SVPBR16-70-45	45	80	70	R	VB..1604..
HSK63T-SVPBL16-70-45	45	80	70	L	VB..1604..
HSK63T-SVPCR16-70-45	45	80	70	R	VC..1604..
HSK63T-SVPCL16-70-45	45	80	70	L	VC..1604..
HSK100T-SVPBR16-100-63	63	120	100	R	VB..1604..
HSK100T-SVPBL16-100-63	63	120	100	L	VB..1604..
HSK100T-SVPCR16-100-63	63	120	100	R	VC..1604..
HSK100T-SVPCL16-100-63	63	120	100	L	VC..1604..

HSK

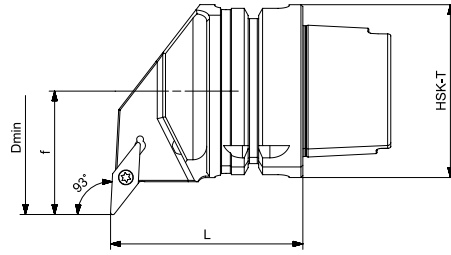
HSK-T Turning Tool SVUBR | SVUBL | SVUCR | SVUCL 93°/35°
正前角刀片

Size	f	D	L	Direction	Inserts N.
HSK63T-SVUBR12-70-45	45	80	70	R	VB..1604..
HSK63T-SVUBL12-70-45	45	80	70	L	VB..1604..
HSK63T-SVUCR12-70-45	45	80	70	R	VC..1604..
HSK63T-SVUCL12-70-45	45	80	70	L	VC..1604..
HSK100T-SVUBR12-100-63	63	120	100	R	VB..1604..
HSK100T-SVUBL12-100-63	63	120	100	L	VB..1604..
HSK100T-SVUCR12-100-63	63	120	100	R	VC..1604..
HSK100T-SVUCL12-100-63	63	120	100	L	VC..1604..

HSK-T Turning Tool SVVBN | SVVCN 72.5°/35°/72.5°

正前角刀片

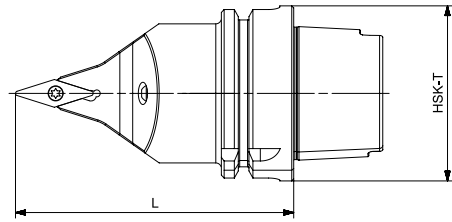

Size	L	Direction	Inserts N.
HSK63T-SVVBN16-100-0	100	N	VB..1604..
HSK63T-SVVBN16-130-0	130	N	VB..1604..
HSK63T-SVVCN16-100-0	100	N	VC..1604..
HSK63T-SVVCN16-130-0	130	N	VC..1604..
HSK100T-SVVBN16-125-0	125	N	VB..1604..
HSK100T-SVVCN16-125-0	125	N	VC..1604..

HSK

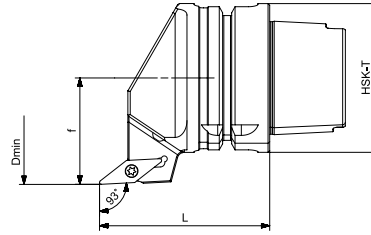
HSK-T Turning Tool SVJBR | SVJBL | SVJCR | SVJCL 93°/35°
正前角刀片

Size	f	D	L	Direction	Inserts N.
HSK63T-SVJBR16-72-45	45	80	71,5	R	VB..1604..
HSK63T-SVJBL16-72-45	45	80	71,5	L	VB..1604..
HSK63T-SVJCR16-72-45	45	80	71,5	R	VC..1604..
HSK63T-SVJCL16-72-45	45	80	71,5	L	VC..1604..
HSK100T-SVJBR16-100-63	63	120	100	R	VB..1604..
HSK100T-SVJBL16-100-63	63	120	100	L	VB..1604..
HSK100T-SVJCR16-100-63	63	120	100	R	VC..1604..
HSK100T-SVJCL16-100-63	63	120	100	L	VC..1604..

HSK-T Turning Tool SCLCR | SCLCL 95°/80°

正前角刀片

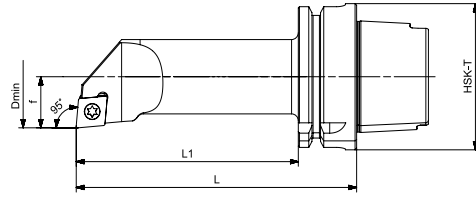

Size	f	D	L	L1	Direction	Inserts N.
HSK63T-SCLCR12-125-22	22	40	125	99	R	CC..1204..
HSK63T-SCLCL12-125-22	22	40	125	99	L	CC..1204..
HSK63T-SCLCR12-160-22	22	40	160	134	R	CC..1204..
HSK63T-SCLCL12-160-22	22	40	160	134	L	CC..1204..
HSK63T-SCLCR12-140-27	27	50	140	114	R	CC..1204..
HSK63T-SCLCL12-140-27	27	50	140	114	L	CC..1204..
HSK63T-SCLCR12-180-27	27	50	180	154	R	CC..1204..
HSK63T-SCLCL12-180-27	27	50	180	154	L	CC..1204..

HSK-T Turning Tool 长型 SDQCR | SDQCL 107.5°/55°

正前角刀片

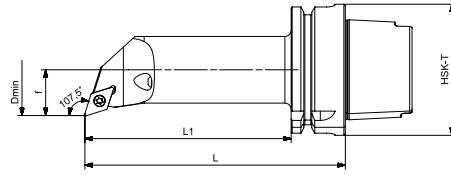

Size	f	D	L	Direction	Inserts N.
HSK63T-SDQCR11-70-45	45	80	70	R	DC..11T3..
HSK63T-SDQCL11-70-45	45	80	70	L	DC..11T3..
HSK100T-SDQCR11-100-63	63	120	100	R	DC..11T3..
HSK100T-SDQCL11-100-63	63	120	100	L	DC..11T3..

HSK-T Turning Tool 长型 SVQCR | SVQCL 107.5°/55°
正前角刀片

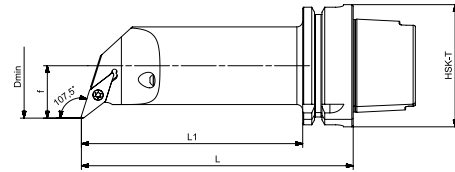

Size	f	D	L	L1	Direction	Inserts N.
HSK63T-SVQCR16-125-22	22	40	125	99	R	VB..T16T3
HSK63T-SVQCL16-125-22	22	40	125	99	L	VB..T16T3
HSK63T-SVQCR16-160-22	22	40	160	134	R	VB..T16T3
HSK63T-SVQCL16-160-22	22	40	160	134	L	VB..T16T3
HSK63T-SVQCR16-140-27	27	50	140	114	R	VB..T16T3
HSK63T-SVQCL16-140-27	27	50	140	114	L	VB..T16T3
HSK63T-SVQCR16-180-27	27	50	180	154	R	VB..T16T3
HSK63T-SVQCL16-180-27	27	50	180	154	L	VB..T16T3